

ALBERTA

Glass: 72" – December 18/97 – 5/97 – 2/99 (Rev.)

Welded Picket: 81" – August 20/98 – 1/98

ITS Intertek Testing Services

REPORT OF: Product Evaluation

AT: Western Railco Plant

DATE: Dec. 18/97

PROJECT: 481-0591

REPORT NO: 5/97 Rev.

REPORTED TO: Western Railco Products Ltd.
13272 Comber Way
Surrey, BC
V3W 6N9

PAGE: 1 of 2

Revised: February 10, 1999

INTRODUCTION

Intertek Testing Services NA Ltd./Warnock Hersey has conducted Uniform and Concentrated load tests on an aluminum guardrail assembly manufactured and tested at Western Railco Products Ltd., manufacturing plant in Surrey, B.C. The rail assembly was identified as the "2000 Series Component (Glass Panel) Rail System" and was tested on October 17 and December 12, 1997.

The testing was conducted in accordance with the National Building Code 1995 edition, Section 4.1.10.1 "Loads on Guards."

DESCRIPTION

The guardrail is (72") wide measured from centre of post to centre of post and (42") high measured from deck level to the top of the guardrail.

The top rail runs continuously over the top of each support post and the bottom rails are fastened to brackets welded to the base of each support post at either side. A 5 mm thick piece of tempered glass is positioned between the top rail and the bottom rail, set on a 3/8" high setting block at 1/4 points and secured within rigid vinyl sleeves top and bottom. A gap of approximately 2" exists at either end of the glazing panel to the support posts. See attached "Plan View" drawing in the appendix for a general layout.

The main support posts are 1-5/8" square complete with a screw chase at each inside corner and a wall thickness of 0.080" thick. The post is welded to the baseplate. The baseplate assembly is 3-1/2" wide x 5-1/2" deep x 1/4" thick and has six holes drill through (see attached drawings for details). Six #14 x 3" stainless steel screws secure each baseplate to a 3" x 10" rough fir timber. The timber itself was quick bolted to the concrete floor of the manufacturing plant. A triangular shaped gusset is not provided between the inside surface of the post and the baseplate.



Warnock Hersey



All services undertaken are subject to the following general policy: Reports are submitted for the exclusive use of client to whom they are addressed. Their significance is subject to the adequacy and representative character of the sample and to the comprehensiveness of the tests, examinations or surveys made. No quotations from reports or use of Intertek Services NA Ltd.'s name is permitted except as expressly authorized by Intertek Testing Services NA Ltd. in writing.

Intertek Testing Services NA Ltd.

211 Schoolhouse Street, Coquitlam, BC V3K 4X9 Canada
Telephone 604-520-3321 Fax 604-524-9186 Home Page www.worldlab.com

TEST RESULTS

1. A uniform load of 0.75 kN/m (51.1 lbs./ft) was applied horizontally outward and normal to the span at the top of the guardrail system.
2. A concentrated load of 0.5 kN (101.2 lbs.) was applied to individual elements within the guard including solid panels.
3. A uniform load of 1.5 kN/m (102.8 lbs./ft) was applied vertically to the top of the guardrail system.

The guardrail assembly withstood the loading conditions as described above which included a 1.5 safety factor.

CONCLUSION

The guardrail system and installation as described in this report (and attached drawings) meets the loading requirements of the National Building Code 1995 Edition, Section 4.1.10.1 "Loads on Guards."

INTERTEK TESTING SERVICES NA LTD.
Warnock Hersey

Tested by:

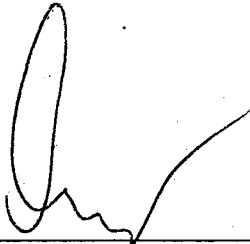

Doug Docherty, AScT
Supervisor
Building Sciences

Reviewed by:



Sheldon Warman, P.Eng.
Manager
Physical Testing and Certification

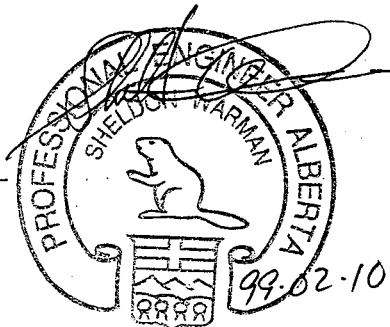

DD/cr

APPENDIX

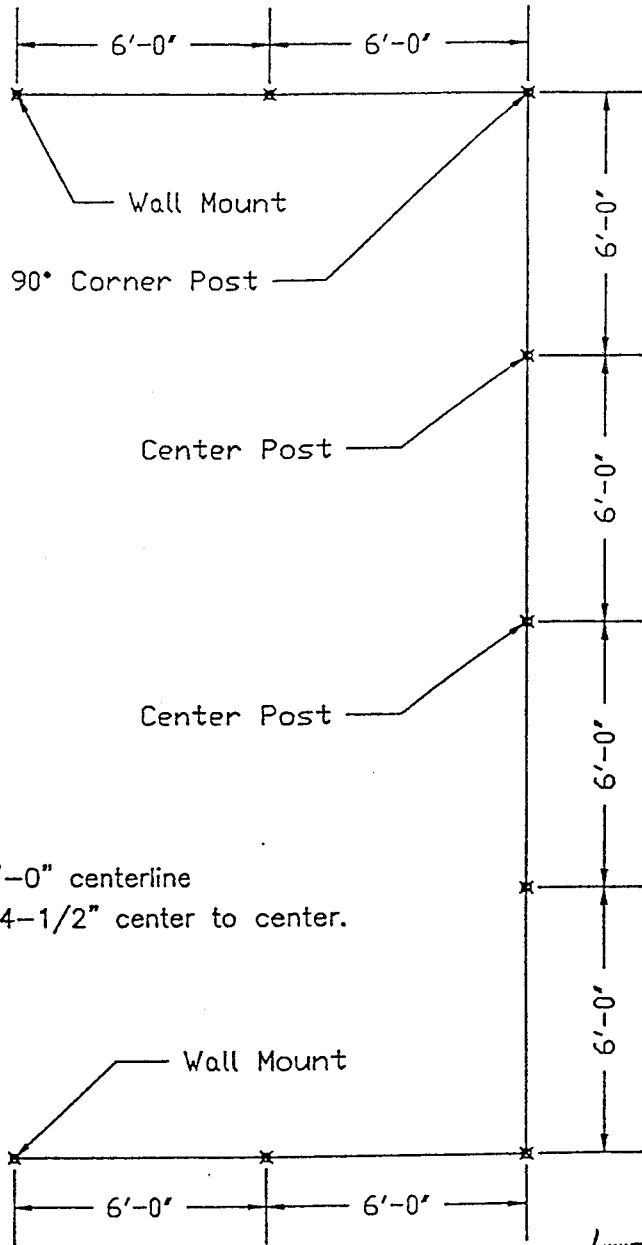

1. All posts are spaced at 6'-0" centerline
2. All pickets are spaced at 4-1/2" center to center.

DWG No. _____

DEC 23 1997

**WESTERN
RAILCO
PRODUCTS LTD.**

13272 COMBER WAY
SURREY, B.C.
CANADA V3W 5V9

Bus. (604) 543-7245
Fax. (604) 543-4447



| | | |
|------------------------|----------------|------------------------------|
| TITLE Test 2 Plan View | | |
| SCALE 1/4" = 1' | DATE Oct.14/97 | |
| DRAFT P.Bacon | CHK'D | |
| ENG | CHK'D | |
| APPR'D | AS BUILT | JOB No. ITS / Warnock Hersey |

DRAWING No.

test 1b



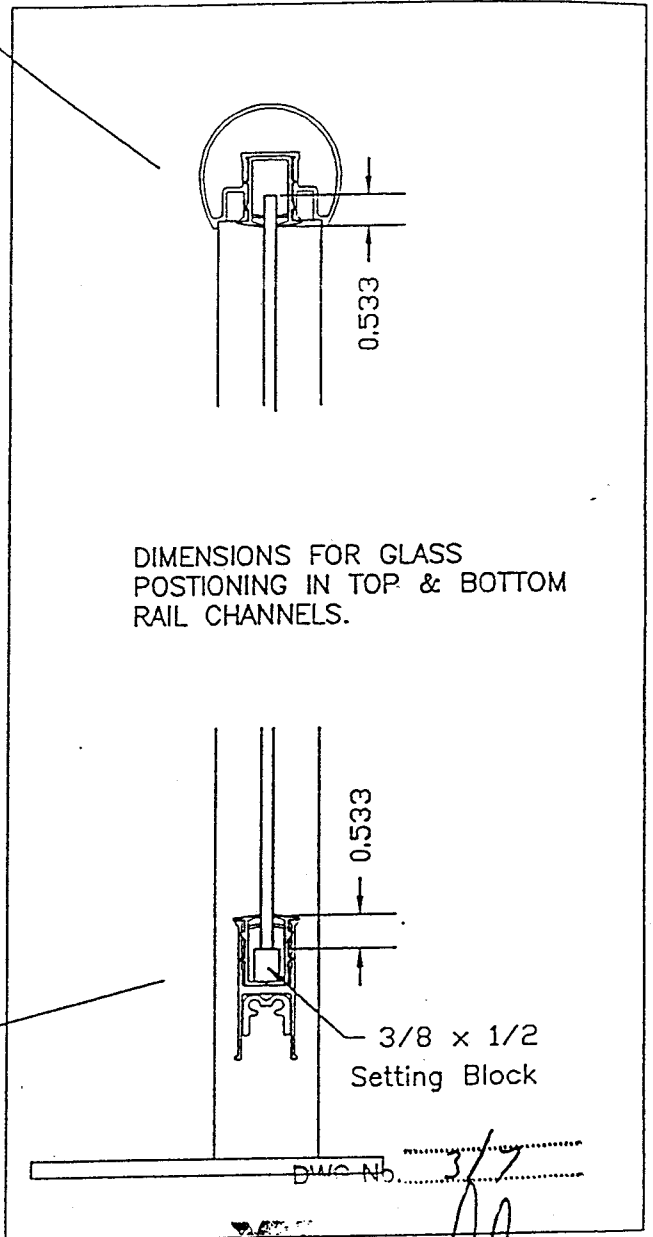
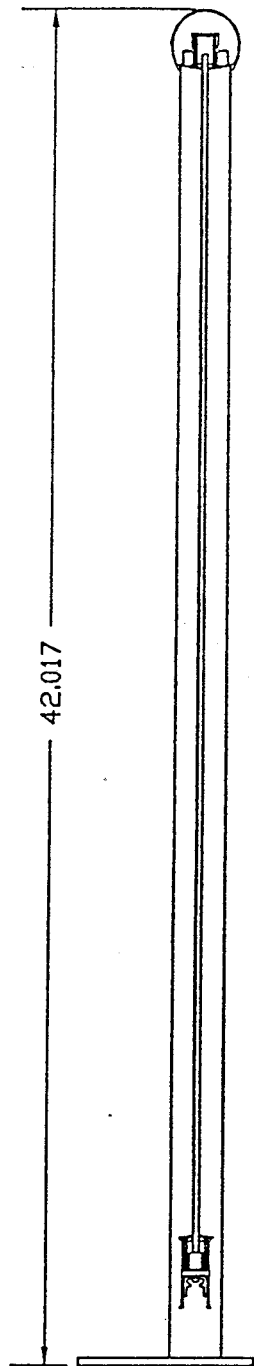

DIMENSIONS FOR GLASS
POSTIONING IN TOP & BOTTOM
RAIL CHANNELS.

**WESTERN
RAILCO
PRODUCTS LTD.**

13272 COMBER WAY
SURREY, B.C.
CANADA V3W 5V9

Bus. (604) 543-7245
Fax. (604) 543-4447

DEC 28 1997
APP BY *[Signature]*



| | | |
|--------------------------------------|----------------|---------|
| TITLE Cross Section of Glass Railing | | |
| SCALE 2" = 1' | DATE Dec.12/97 | |
| DRAFT P.Bacon | CHK'D | |
| ENG | CHK'D | |
| APPR'D | AS BUILT | JOB No. |

DRAWING No. C-Sec 0

TOP RAILS



2000-R
Small Round



2000-S
New Small Sq.

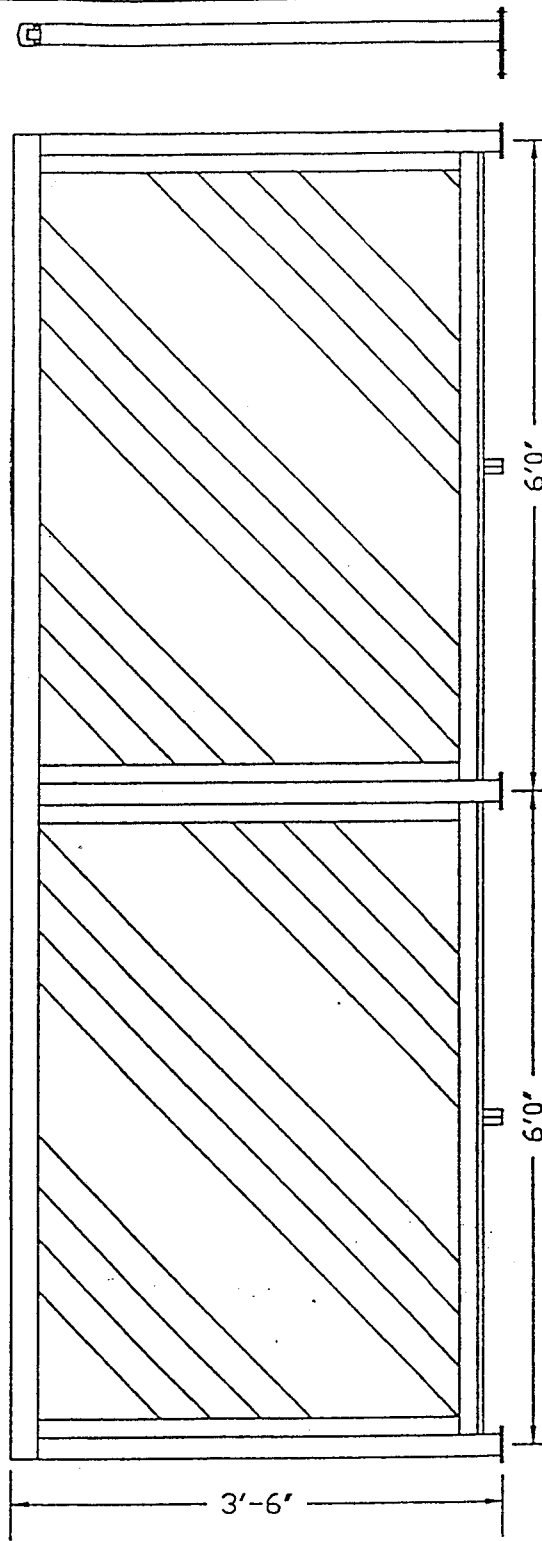

SUPPORT LEG



New H-Rail
Support Leg

BOTTOM RAIL



Deep H-Rail

POST MATERIAL



1-5/8" Square
Post Mount Plate

**WESTERN
RAILCO
PRODUCTS LTD.**

13272 COMBER WAY
SURREY, B.C.
CANADA V3W 5V9

Bus. (604) 543-7245
Fax. (604) 543-4447

DWG No. 2/7

DEC 23 1997

APP BY [Signature]

TITLE 1-5/8" GLASS SYSTEM ASSEMBLY-FULL HEIGHT @ 42"

SCALE 3/4" = 1'

DATE Oct. 14/97

DRAFT P. Bacon

CHK'D

ENG

CHK'D

APPR'D

AS BUILT

JOB No. ITS / Warnock Hersey

DRAWING No.

001b



TM



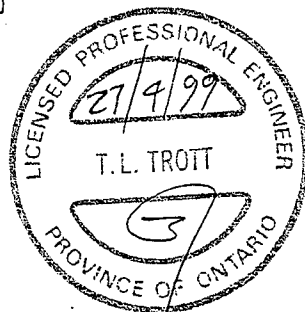
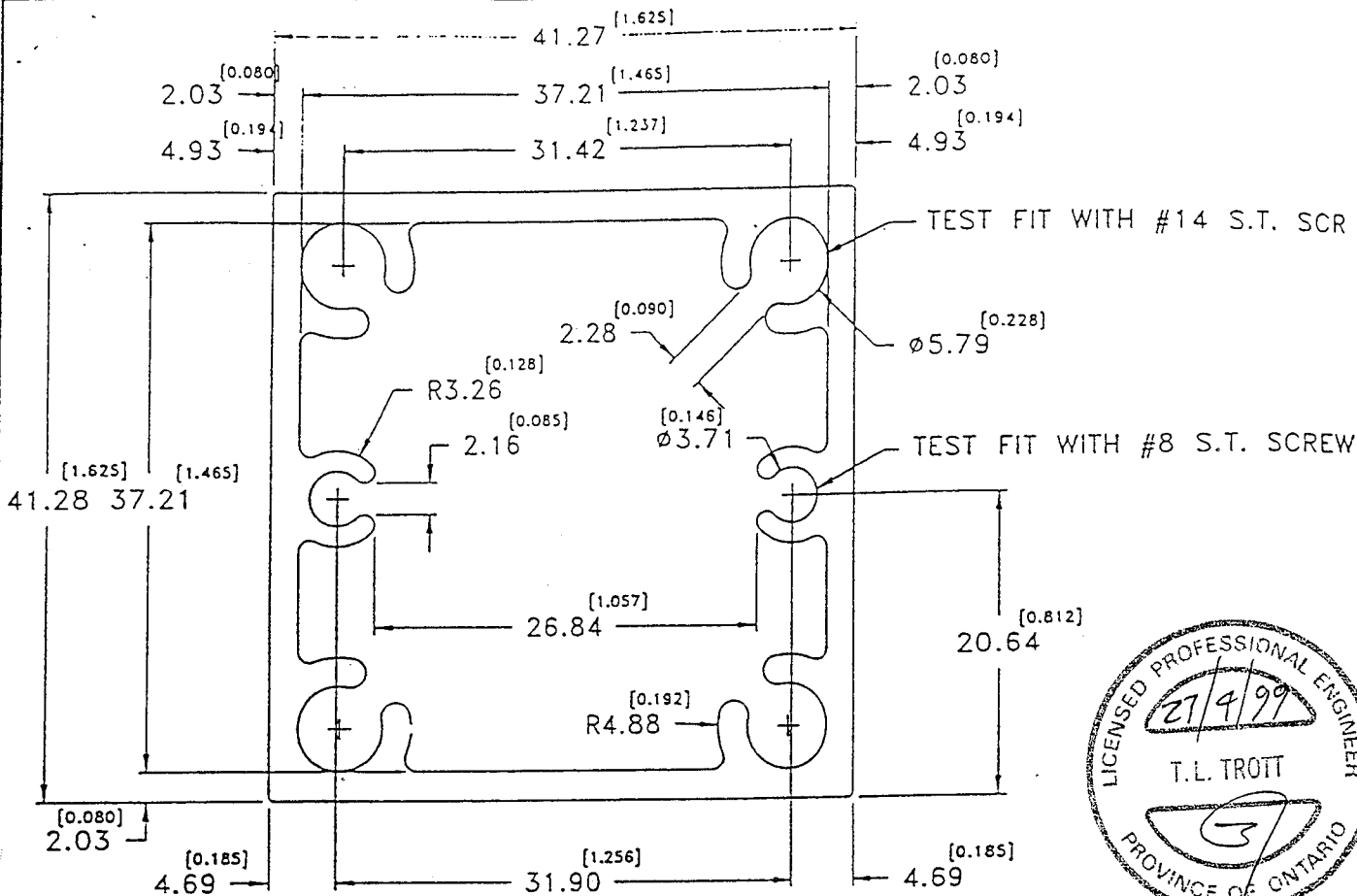

WALL THICKNESS AS SHOWN
 UNMARKED RADII 0.80^[0.031]
 BREAK SHARP CORNERS 0.38R^[0.015]

ALL EXTERIOR SURFACES EXPOSED

DWG NO. 4/7

DEC 28 1997

APP BY

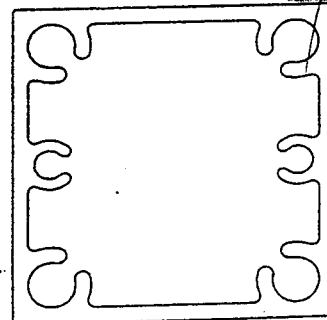

ACTUAL SIZE

| | | | |
|-----------|--|--|--|
| REVISIONS | | | |
| | | | |
| | | | |
| | | | |
| | | | |

Kawneer
 COMPANY CANADA LIMITED
 KAWNEER COMPANY CANADA LTD.
 4000-18 AVE N LETHBRIDGE AB.
 T1H 5S8 TEL (403)320-7755

| | | | |
|---------------------|-------------|--------|-------|
| ESTIMATED AREA | SQ.IN. | 443.49 | SQ.MM |
| ESTIMATED WEIGHT | 0.808 LB/FT | 1.203 | KG/M |
| ESTIMATED PERIMETER | 6.478 IN. | 164.53 | MM |
| EST. PER. INTERIOR | 9.372 IN. | 238.04 | MM |

CUSTOMER WESTERN RAILCO PRODUCTS LTD.
 CITY SURREY PROV. B.C.

CUST. PART NO. LOCATION OF I.D. MARK SEE T-2013

SCALE 2X FULL DATE FEB 24/97

STANDARD COMMERCIAL TOLERANCES FOR EXTRUDED ROD, BAR & SHAPES APPLY UNLESS SPECIFICALLY SHOWN OTHERWISE

ALUMINUM EXTRUDED PRODUCTS ALLOY 6063 TEMPER T54

END USE CCD = 2.287 in.

DIE COST: TSP TS-3385

DIE DWG. 660-306

DATE

This is not a Kawneer design. It is Kawneer's interpretation of the section designed and requested by its customer. Customer should thoroughly check the drawing and test the design before using, as Kawneer accepts no responsibility or liability for the performance of products produced therefrom. Kawneer makes no warranty of fitness for a particular purpose with regard to the extrusions produced pursuant to this drawing. Kawneer's standard terms and conditions apply.

CUSTOMER'S APPROVAL

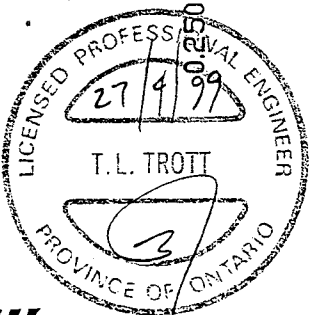
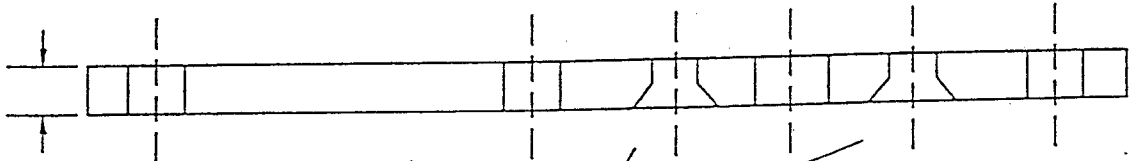
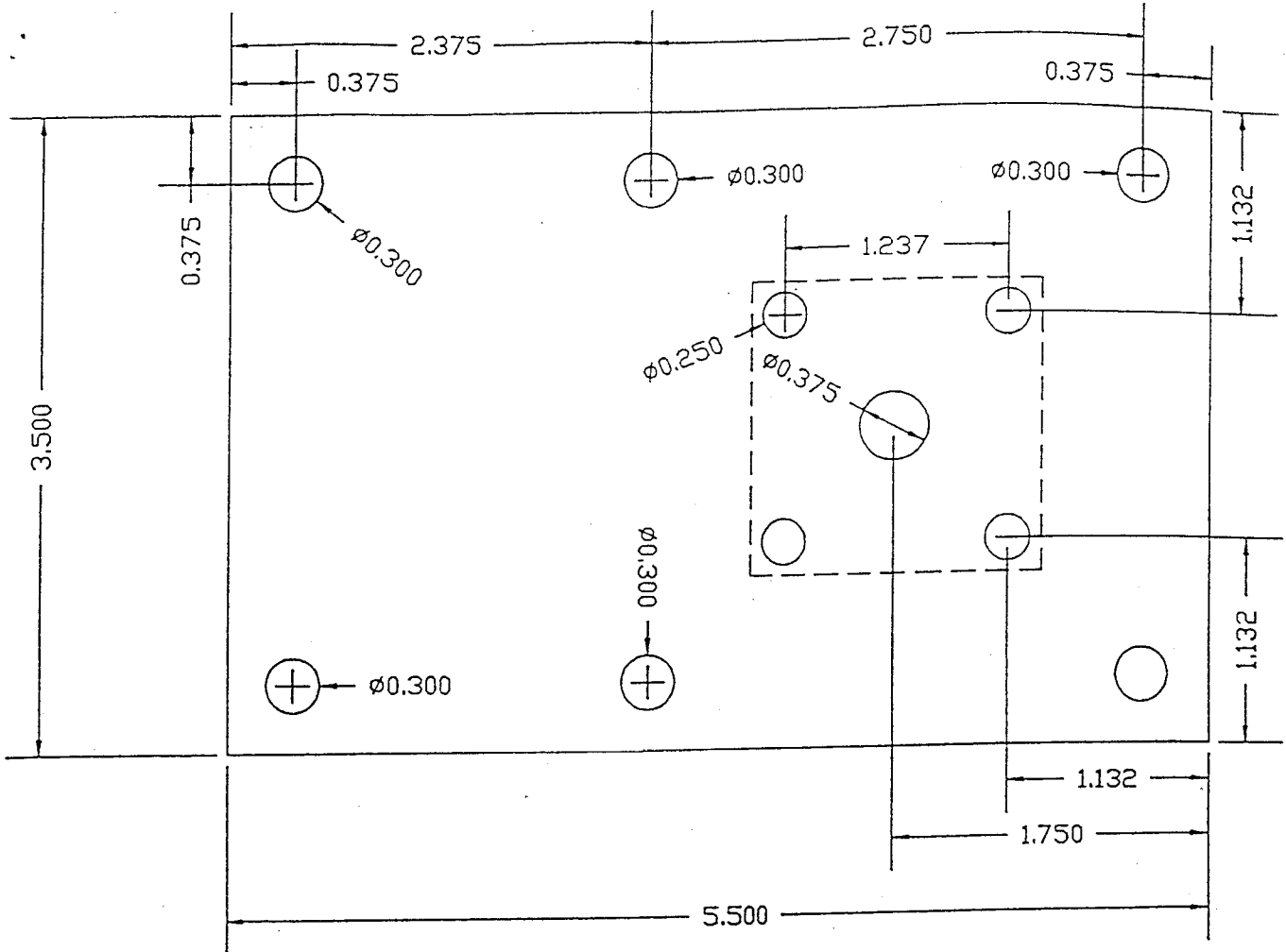

4 HOLES COUNTERSUNK FOR #14 TAPERED SCREW.

DWG No. 5/7

DEC 23 1997

APP BY

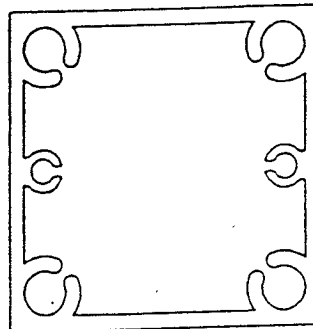

**WESTERN
 RAILCO
 PRODUCTS LTD.**

13272 COMBER WAY
 SURREY, B.C.
 CANADA V3W 5V9

Bus. (604) 543-7245
 Fax. (604) 543-4447



| | | |
|---------------------------|----------------|---------|
| TITLE Screw On Base Plate | | |
| SCALE 1:1 | DATE June 6/97 | |
| DRAFT P.Bacon | CHK'D | |
| ENG | CHK'D | |
| APPR'D | AS BUILT | JOB No. |

DRAWING No.
BASE1

0

